

IGBT Discrete

V_{CE}	650	V
I_C	50	A
$V_{CE(SAT)} I_C=50A$	1.60	V

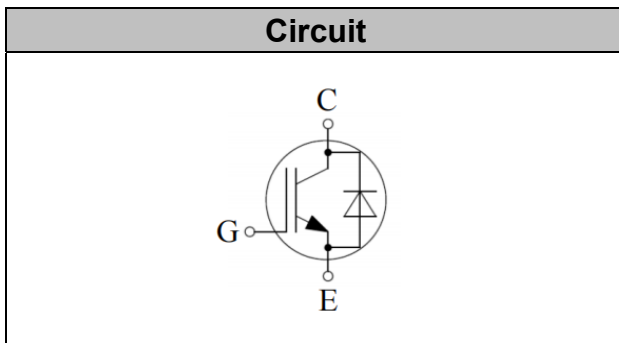

Applications

- High frequency switching application
- Resonant converters
- Uninterruptible power supply
- Welding converters

Features

- High speed smooth switching device for hard & soft switching
- Maximum junction temperature 175°C
- Positive temperature coefficient
- High ruggedness, temperature stable
- Pb-free lead plating; RoHS compliant

Maximum Ratings

Parameter	Symbol	Value	Unit
Collector-Emitter Breakdown Voltage	V_{CE}	650	V
DC Collector Current, limited by T_{jmax} $T_C=25^\circ C$ value limited by bondwire $T_C=100^\circ C$	I_C	85 60	A
Diode Forward Current, limited by T_{jmax} $T_C=25^\circ C$ value limited by bondwire $T_C=100^\circ C$	I_F	85 60	A
Continuous Gate-Emitter Voltage	V_{GE}	± 20	V
Transient Gate-Emitter Voltage ($t_p \leq 10\mu s, D < 0.010$)	V_{GE}	± 30	V
Turn off Safe Operating Area $V_{CE} \leq 650V$, $T_j \leq 150^\circ C$		200	A
Pulsed Collector Current, $V_{GE}=15V$, t_p limited by T_{jmax}	I_{CM}	200	A
Diode Pulsed Current, t_p limited by T_{jmax}	I_{Fpuls}	200	A
Power Dissipation, $T_j=175^\circ C$, $T_C=25^\circ C$	P_{tot}	326	W



Operating Junction Temperature	T_j	-40...+175	°C
Storage Temperature	T_s	-55...+150	°C
Soldering Temperature, wave soldering 1.6mm (0.063in.) from case for 10s		260	°C

Electrical Characteristics of the IGBT ($T_j = 25^\circ\text{C}$ unless otherwise specified):

Parameter	Symbol	Conditions	Min.	Typ.	Max.	Unit
Static						
Collector-Emitter Breakdown Voltage	BV_{CES}	$V_{GE}=0V, I_C=250\mu A$	650		-	V
Gate Threshold Voltage	$V_{GE(th)}$	$V_{GE}=V_{CE}, I_C=0.5mA$	4.25	5.05	5.85	V
Collector-Emitter Saturation Voltage	$V_{CE(sat)}$	$V_{GE}=15V, I_C=50A$ $T_j=25^\circ\text{C}$, $T_j=125^\circ\text{C}$ $T_j=150^\circ\text{C}$	1.45	1.60 1.95 2.05	1.95	V
Zero Gate Voltage Collector Current	I_{CES}	$V_{CE}=650V, V_{GE}=0V$ $T_j=25^\circ\text{C}$, $T_j=150^\circ\text{C}$			0.25 3.00	mA
Gate-Emitter Leakage Current	I_{GES}	$V_{CE}=0V, V_{GE}=20V$			200	nA

Parameter	Symbol	Conditions	Min.	Typ.	Max.	Unit
Dynamic						
Input Capacitance	C_{ies}	$V_{CE}=25V, V_{GE}=0V,$ $f=1MHz$	-	5.92	-	nF
Reverse Transfer Capacitance	C_{res}		-	0.11	-	
Gate Charge	Q_G	$V_{CC}=300V, I_C=50A,$ $V_{GE}=-5V\sim+15V$	-	0.42	-	uC



Switching Characteristic, Inductive Load

Parameter	Symbol	Conditions	Min.	Typ.	Max.	Unit
Dynamic , at T_j= 25°C						
Turn-on Delay Time	t _{d(on)}	V _{CC} =300V, I _C =50A, V _{GE} = 0V~15V, R _g =10Ω,L _s =60nH	-	55	-	ns
Rise Time	t _r		-	56	-	ns
Turn-on Energy	E _{on}		-	1.27	-	mJ
Turn-off Delay Time	t _{d(off)}		-	319	-	ns
Fall Time	t _f		-	24	-	ns
Turn-off Energy	E _{off}		-	0.65	-	mJ
Total switching energy	E _{ts}		-	1.92	-	mJ
Dynamic , at T_j= 125°C						
Turn-on Delay Time	t _{d(on)}	V _{CC} =300V, I _C =50A, V _{GE} = 0V~15V, R _g =10Ω,L _s =60nH	-	53	-	ns
Rise Time	t _r		-	61	-	ns
Turn-on Energy	E _{on}		-	1.51	-	mJ
Turn-off Delay Time	t _{d(off)}		-	351	-	ns
Fall Time	t _f		-	59	-	ns
Turn-off Energy	E _{off}		-	0.80	-	mJ
Total switching energy	E _{ts}		-	2.31	-	mJ
Dynamic , at T_j= 150°C						
Turn-on Delay Time	t _{d(on)}	V _{CC} =300V, I _C =50A, V _{GE} = 0V~15V, R _g =10Ω,L _s =60nH	-	52	-	ns
Rise Time	t _r		-	60	-	ns
Turn-on Energy	E _{on}		-	1.62	-	mJ
Turn-off Delay Time	t _{d(off)}		-	361	-	ns
Fall Time	t _f		-	71	-	ns
Turn-off Energy	E _{off}		-	0.85	-	mJ
Total switching energy	E _{ts}		-	2.47	-	mJ



Electrical Characteristics of the Diode (T_j= 25°C unless otherwise specified):

Parameter	Symbol	Conditions	Min.	Typ.	Max.	Unit
Static						
Diode Forward Voltage	V _F	I _F = 50A T _j = 25°C, T _j = 125°C T _j = 150°C	1.30	1.45 1.29 1.23	1.90	V

Electrical Characteristics of the DIODE

Parameter	Symbol	Conditions	Min.	Typ.	Max.	Unit
Dynamic , at T_j= 25°C						
Reverse Recovery Current	I _{rr}	I _F =50A, V _R =300V -di/dt= 610A/μs,	-	13	-	A
Reverse Recovery Charge	Q _{rr}		-	0.78	-	uC
Diode reverse recovery time	t _{rr}		-	100	-	ns
Reverse Recovery Energy	E _{rec}		-	0.1	-	mJ
Dynamic , at T_j= 125°C						
Reverse Recovery Current	I _{rr}	I _F =50A, V _R =300V -di/dt= 610A/μs,	-	35	-	A
Reverse Recovery Charge	Q _{rr}		-	2.8	-	uC
Diode reverse recovery time	t _{rr}		-	140	-	ns
Reverse Recovery Energy	E _{rec}		-	0.38	-	mJ
Dynamic , at T_j= 150°C						
Reverse Recovery Current	I _{rr}	I _F =50A, V _R =300V -di/dt= 610A/μs,	-	40	-	A
Reverse Recovery Charge	Q _{rr}		-	3.22	-	uC
Diode reverse recovery time	t _{rr}		-	160	-	ns
Reverse Recovery Energy	E _{rec}		-	0.43	-	mJ



Thermal Resistance

Parameter	Symbol	Max. Value	Unit
IGBT Thermal Resistance, Junction - Case	$R_{th(j-c)}$	0.46	K/W
Diode Thermal Resistance, Junction - Case	$R_{th(j-c)}$	0.51	K/W
Thermal Resistance, Junction - Ambient	$R_{th(j-a)}$	40	K/W

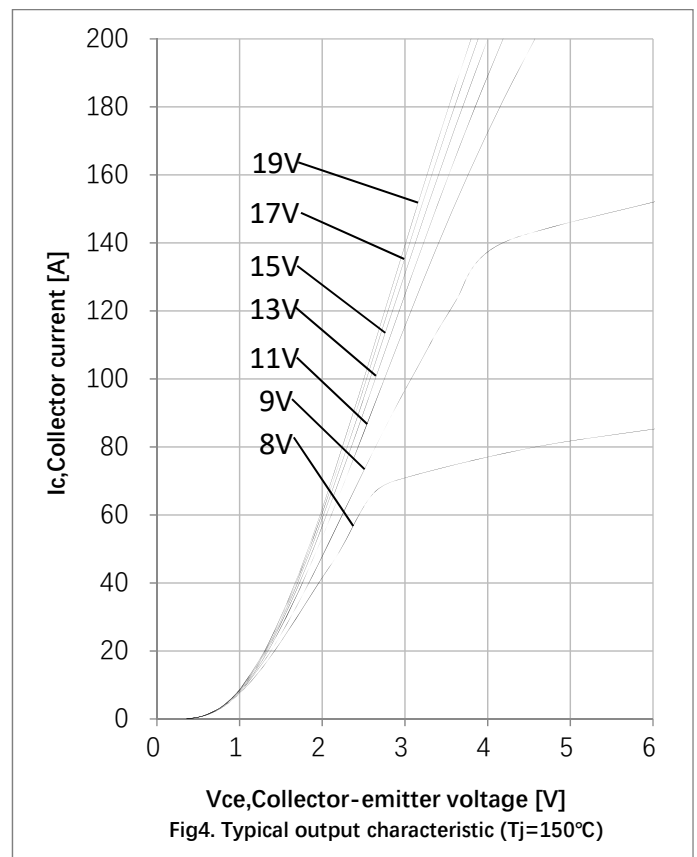
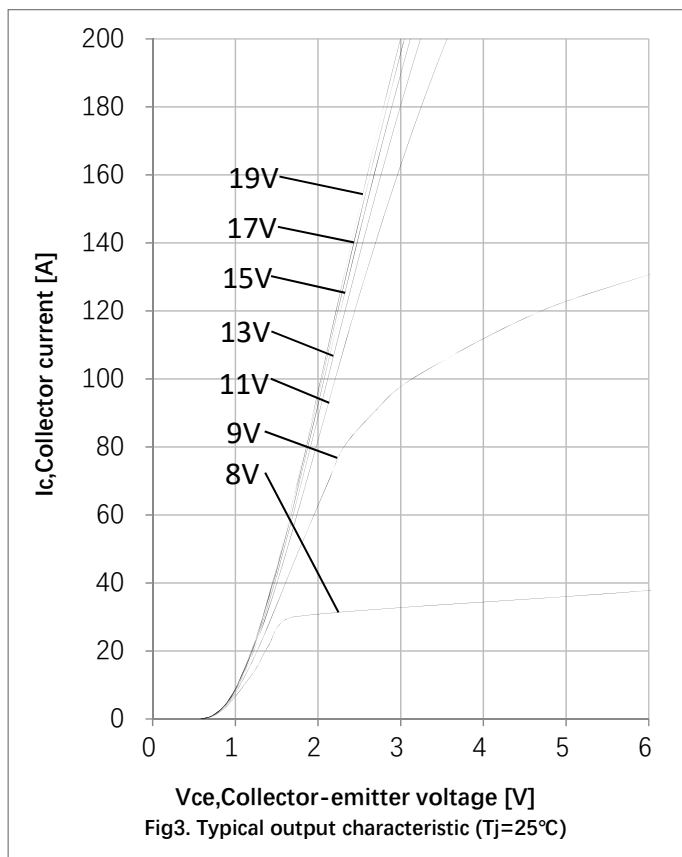
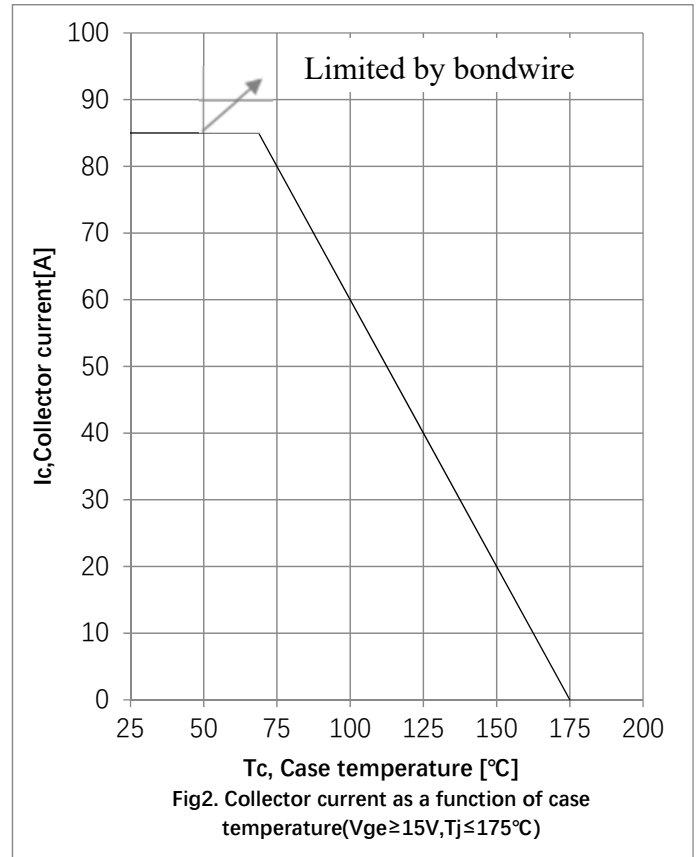
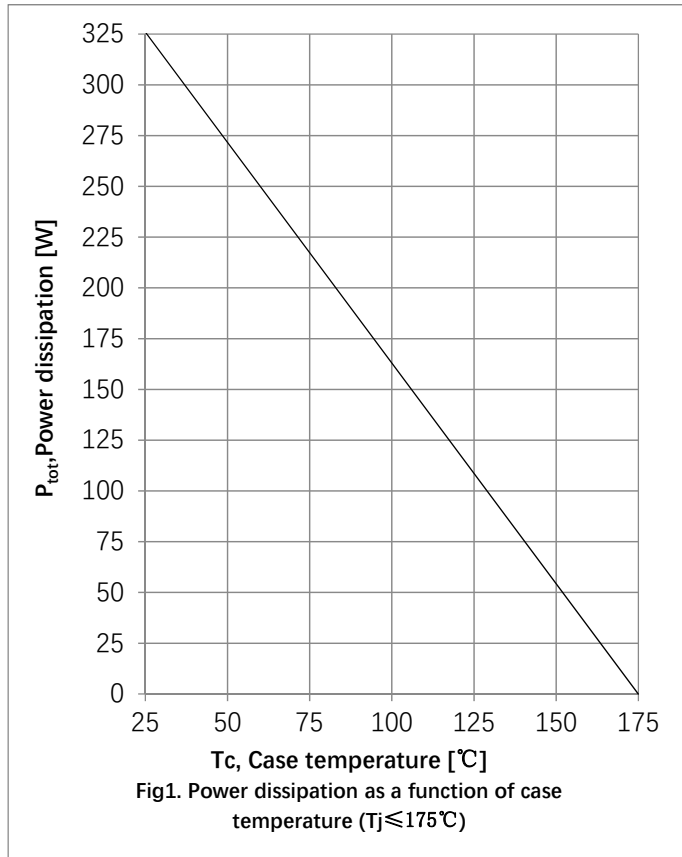

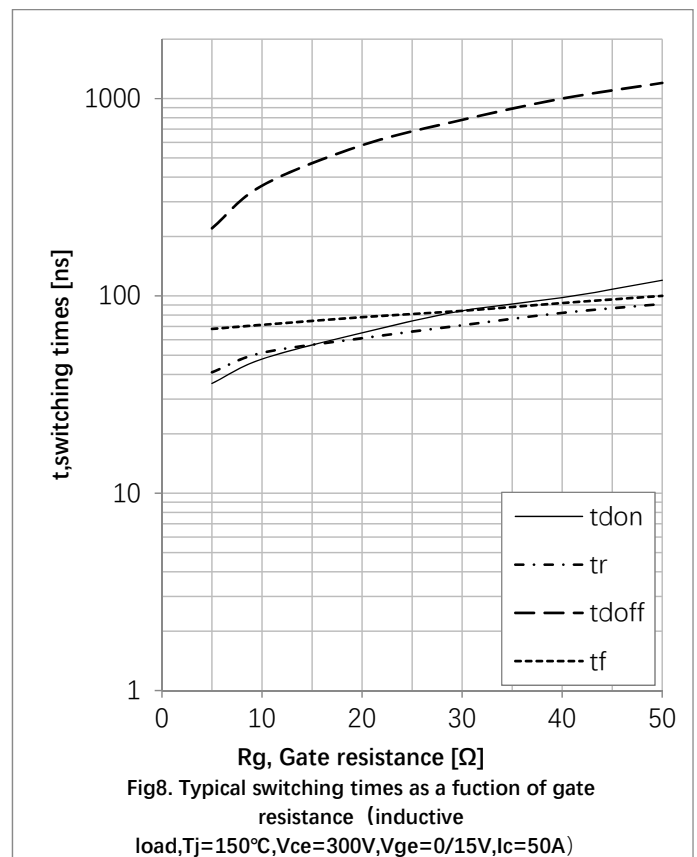
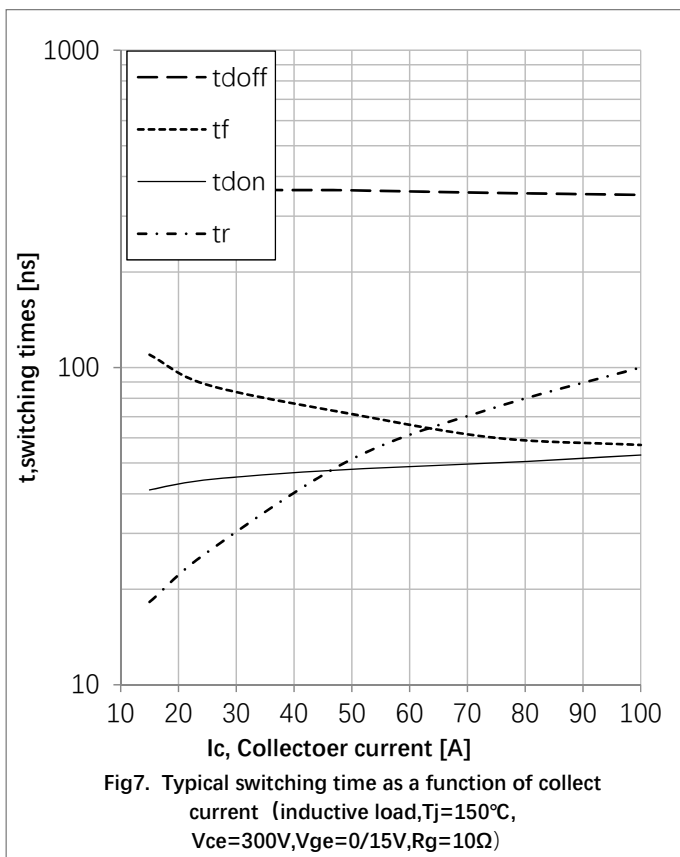
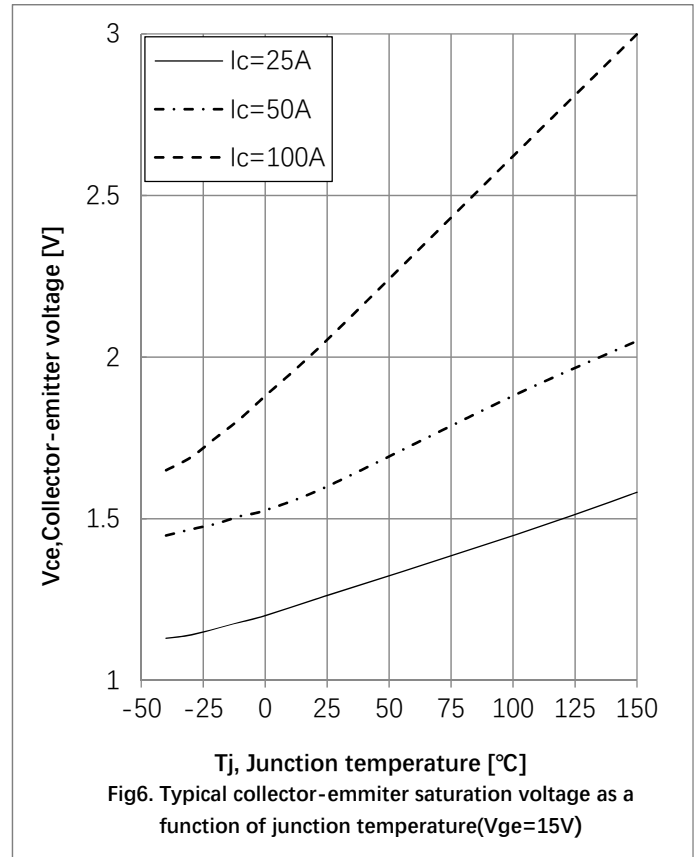
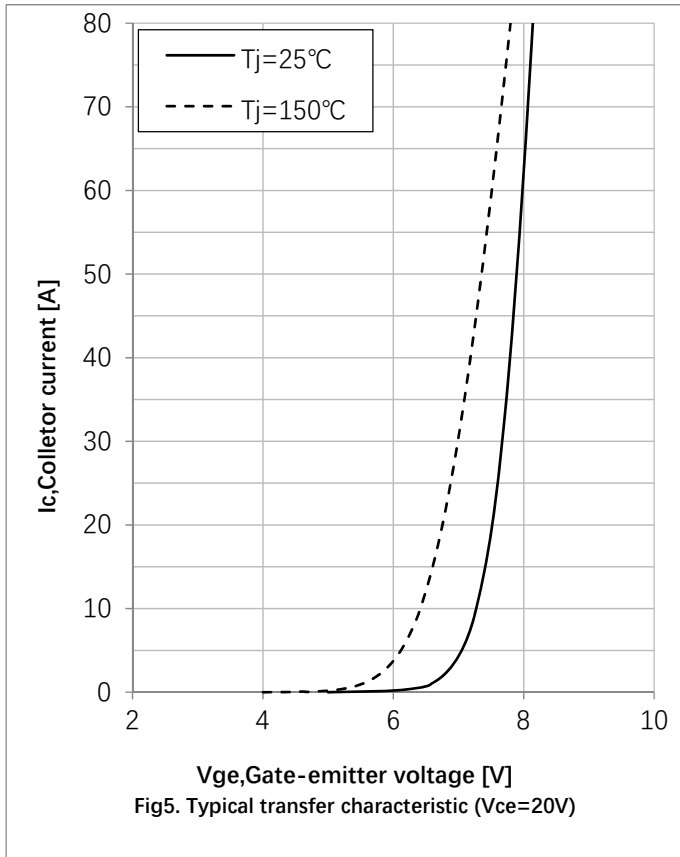

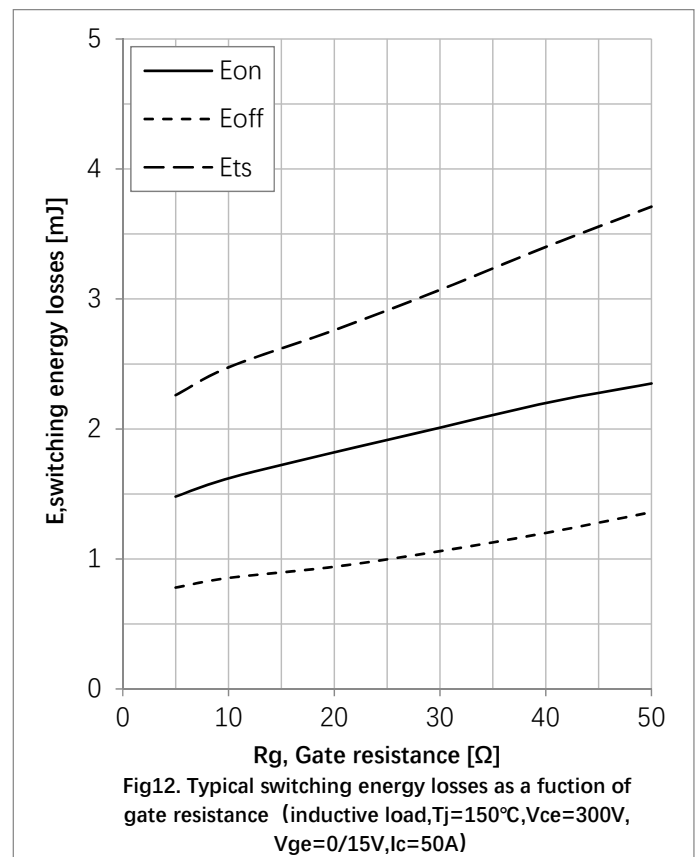
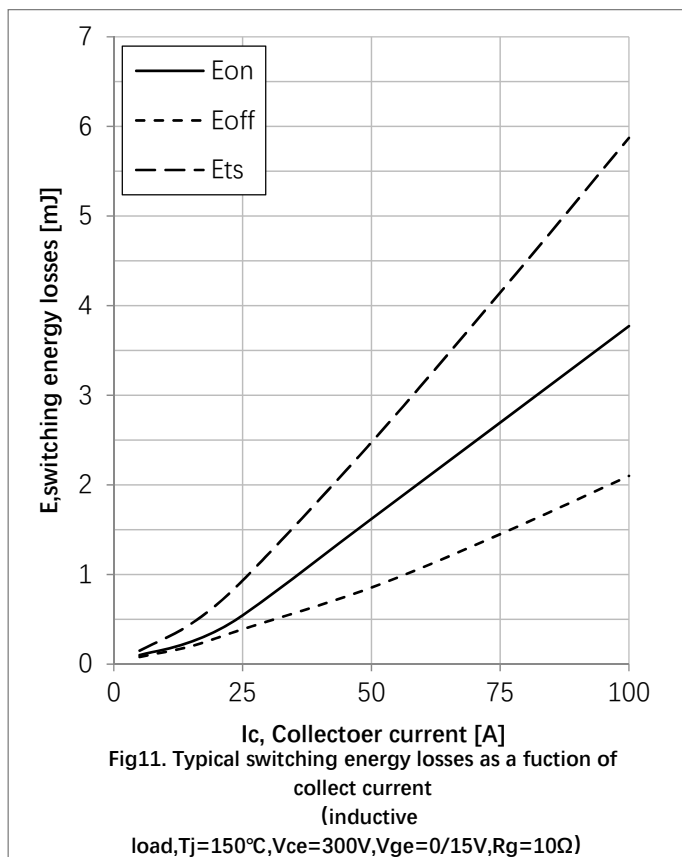
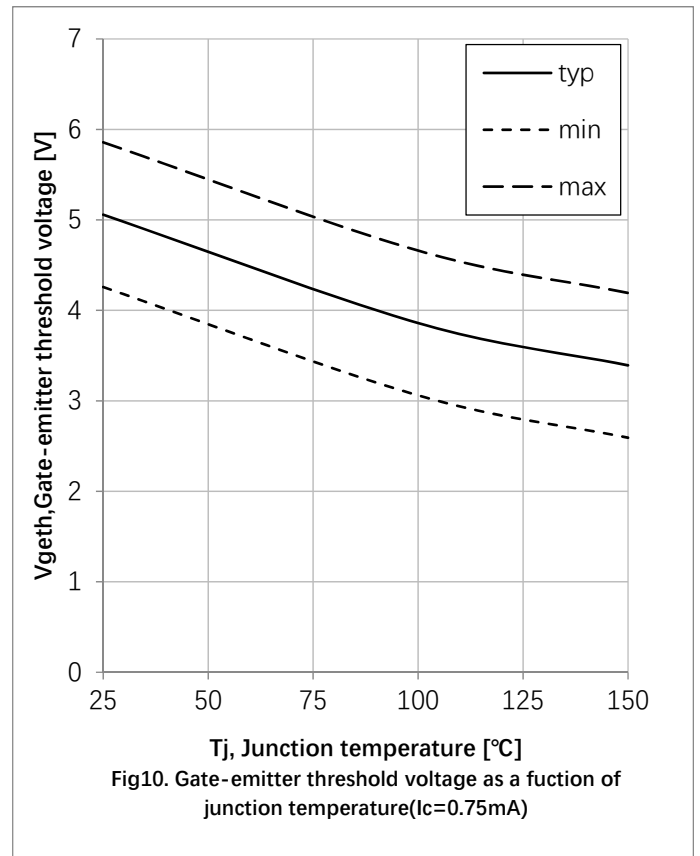
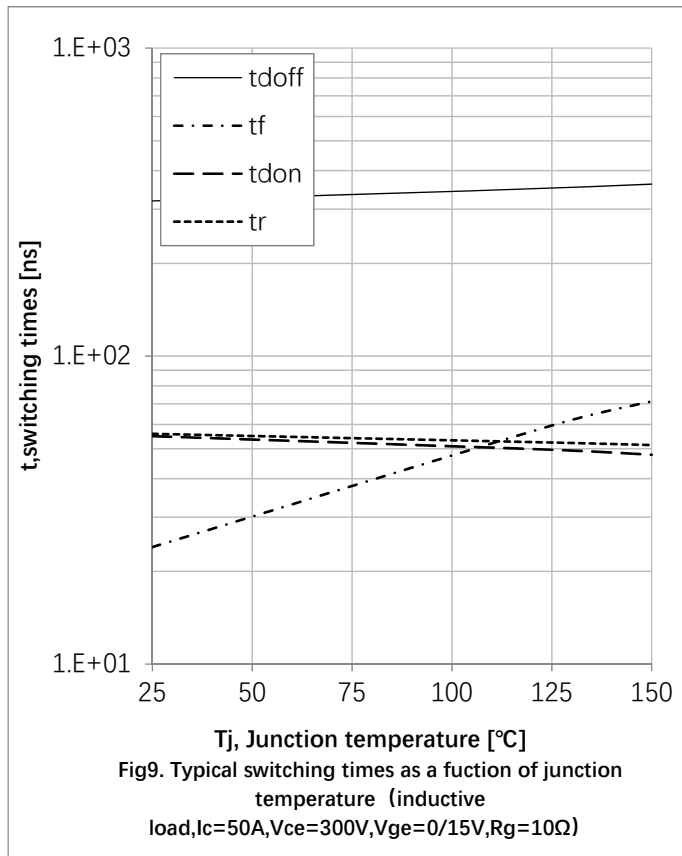

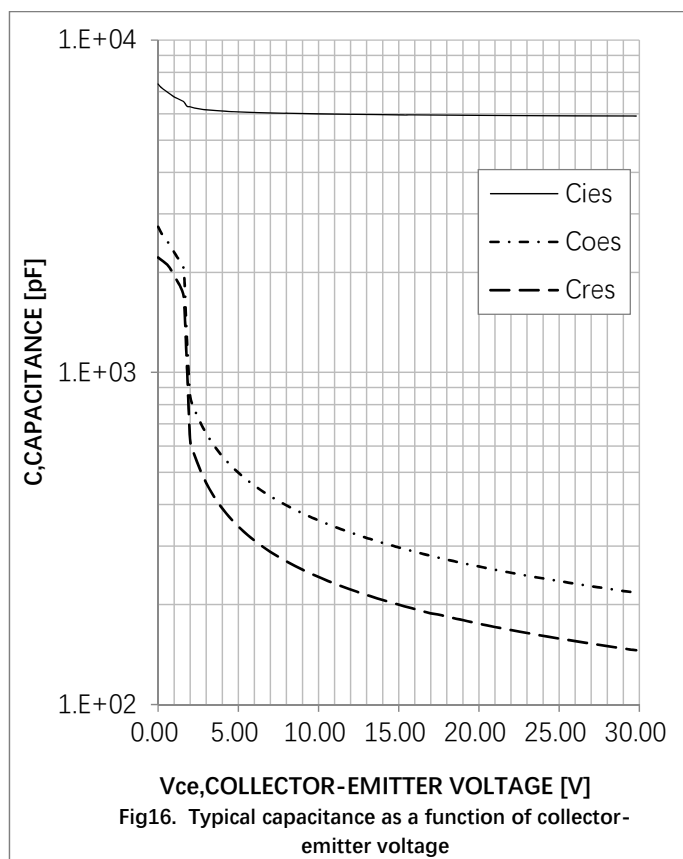
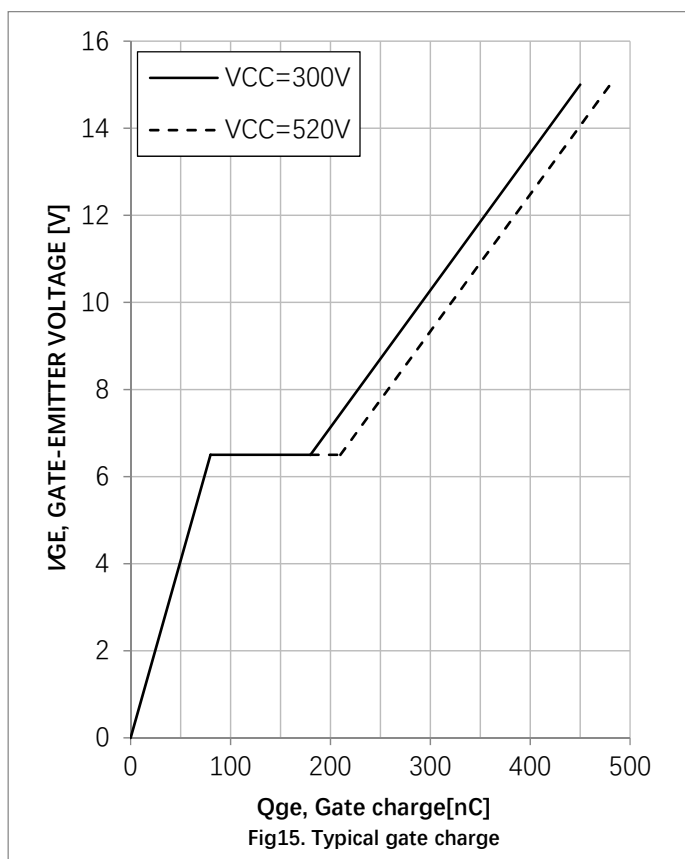
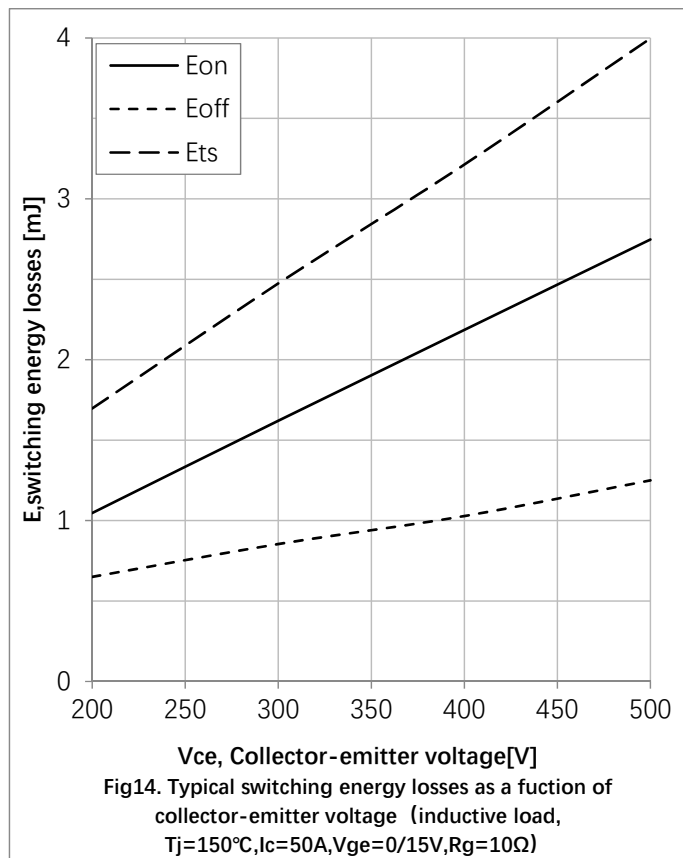
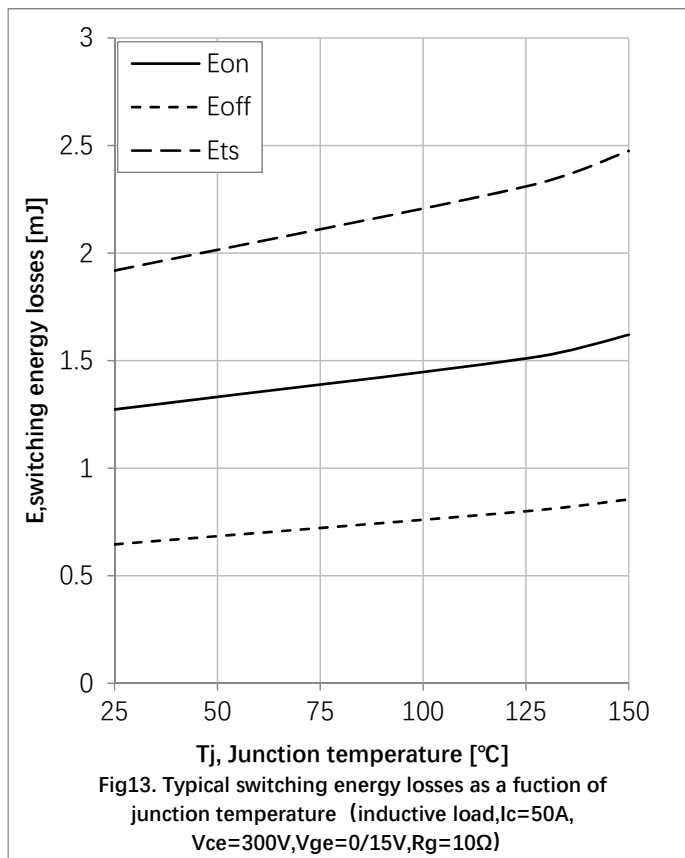

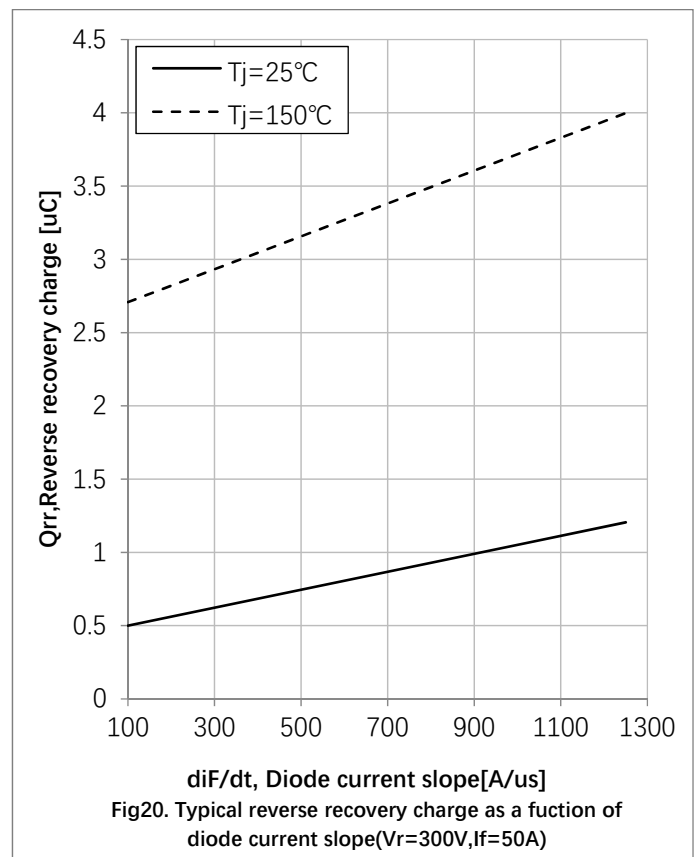
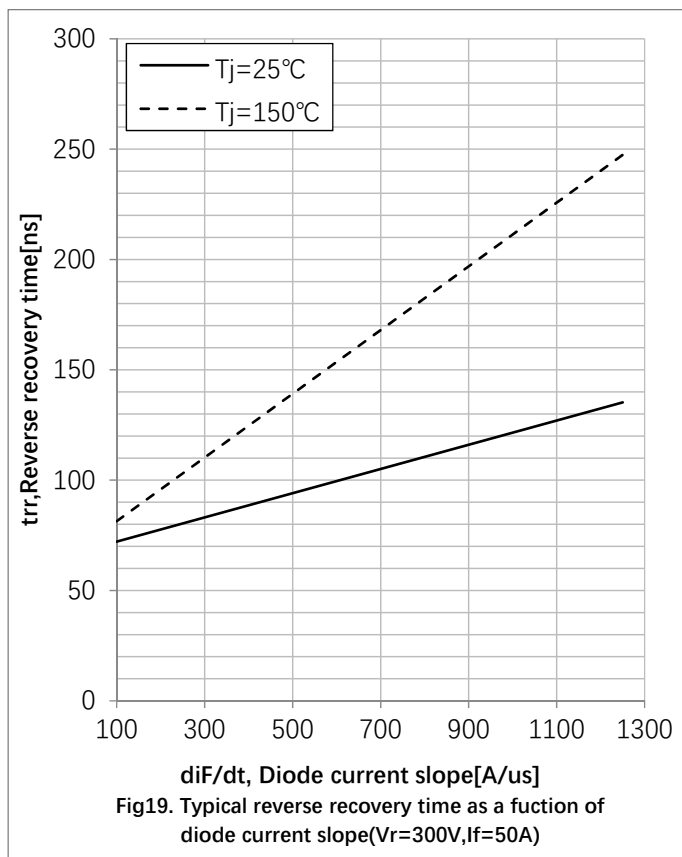
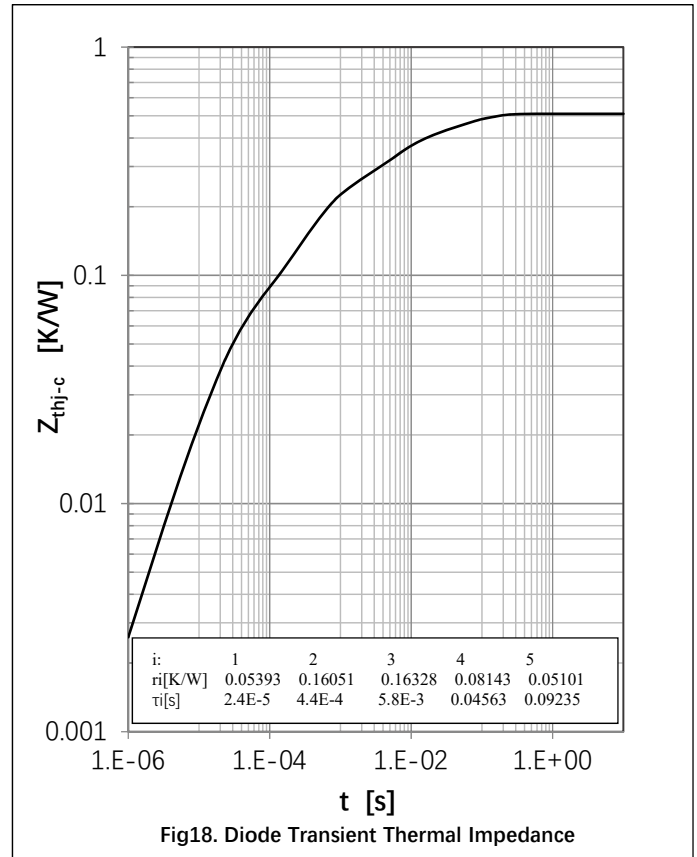
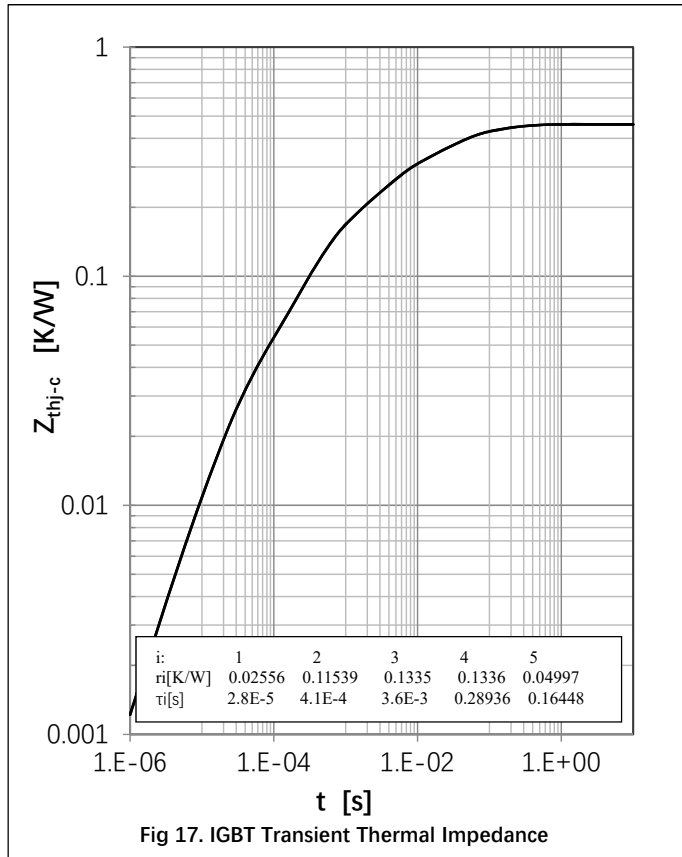

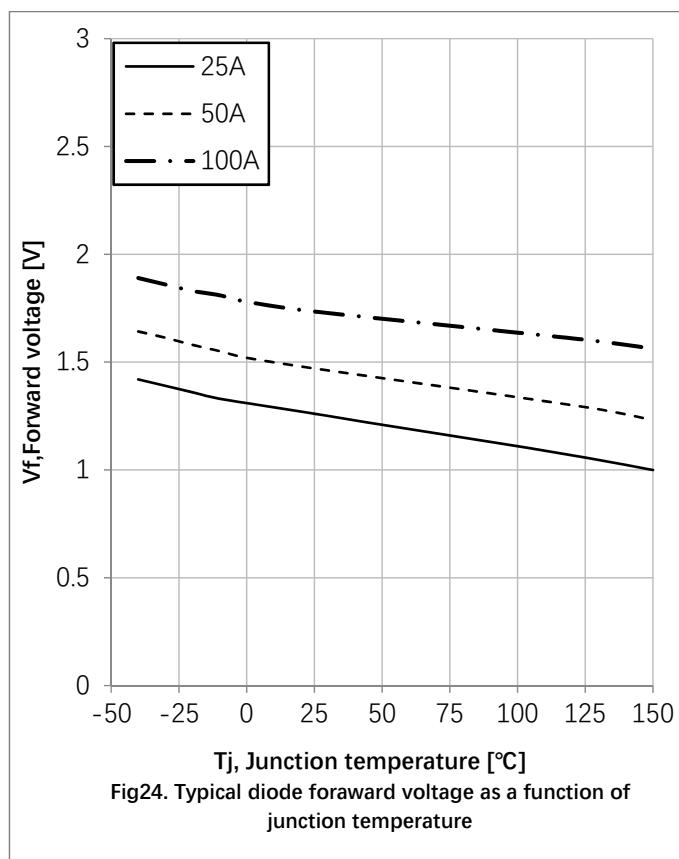
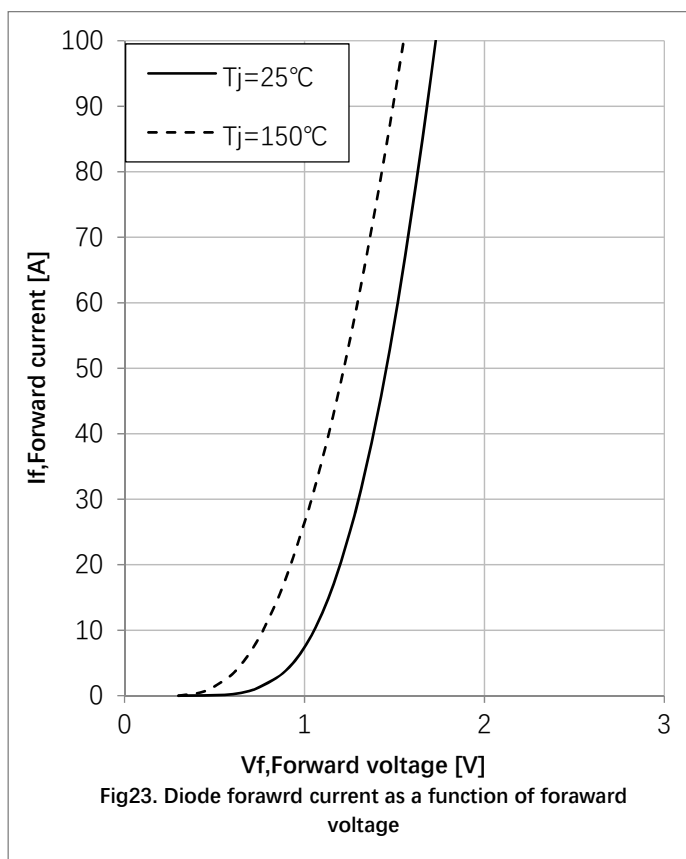
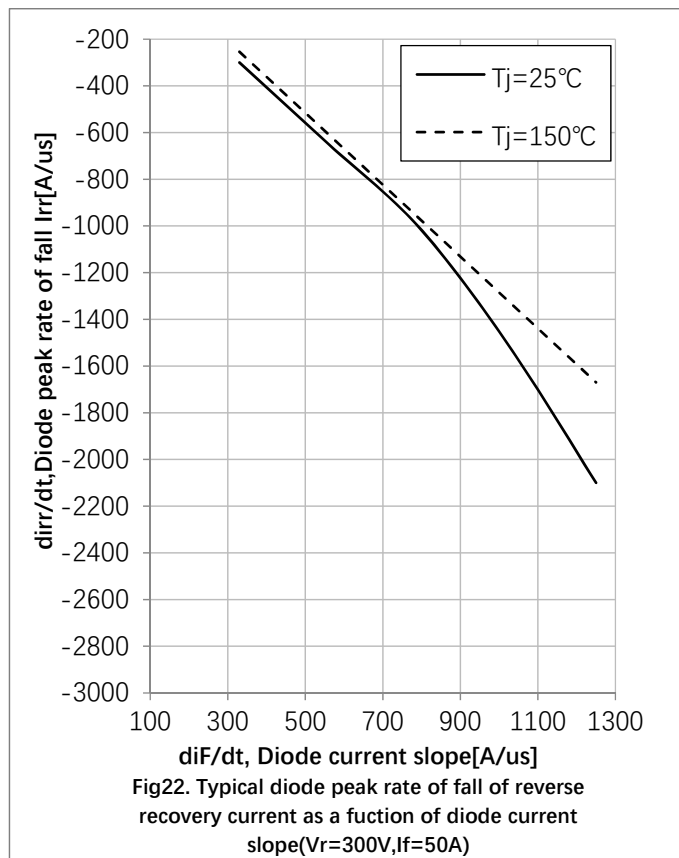
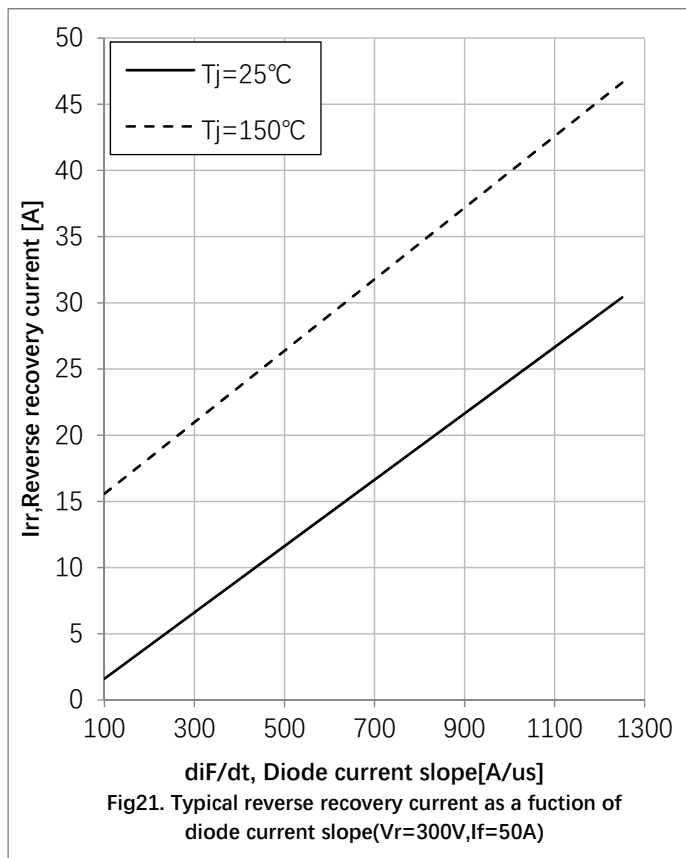

● Circuit Diagram

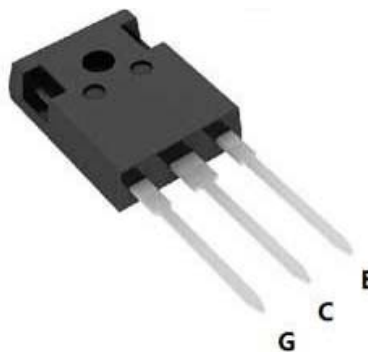
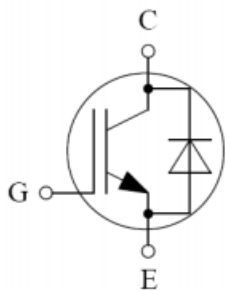

● Package Outline Information

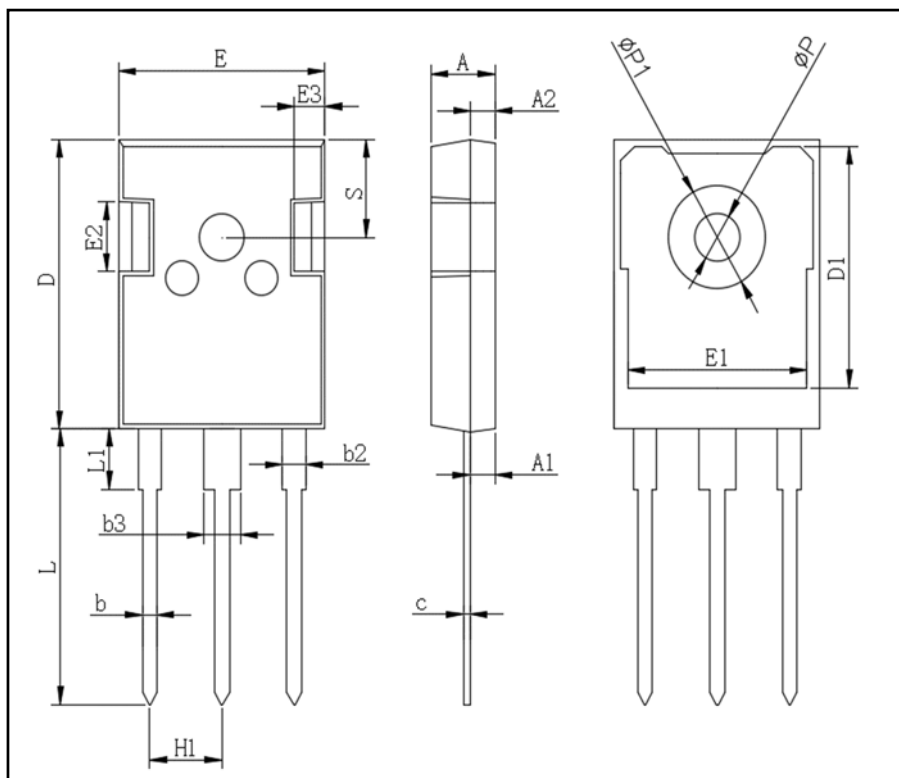

TO-247AB		
Dim	Min	Max
A	4.80	5.20
A1	2.21	2.61
A2	1.85	2.15
b	1.0	1.4
b2	1.91	2.21
C	0.5	0.7
D	20.70	21.30
D1	16.25	16.85
E	15.50	16.10
E1	13.0	13.6
E2	4.80	5.20
E3	2.30	2.70
L	19.62	20.22
L1	-	4.30
ΦP	3.40	3.80
ΦP1	-	7.30
S	6.15TYP	
H1	5.44TYP	
b3	2.80	3.20